

DESCRIPTION

Single Port PD(Powered Device) Integrated Module (Isolation Type)

FEATURES

- Fully Supports IEEE802.3bt Compliant (Type-3 and Single-Signature 4-pair)
- **Embedded Dual Active Bridge** (No need to add 2 Bridge-Diodes)
- Short Circuit, Over-temperature Protection and In-rush Current Limit
- Input Voltage Range : 41V to 57V for Full Power Rate
- Default Class : 5
- Maximum Output Power : 40W
- High Efficiency (90% min. @Full Load)
- Easy Installation and Low Cost
- Low Output Ripple and Noise
- RoHS Compliant

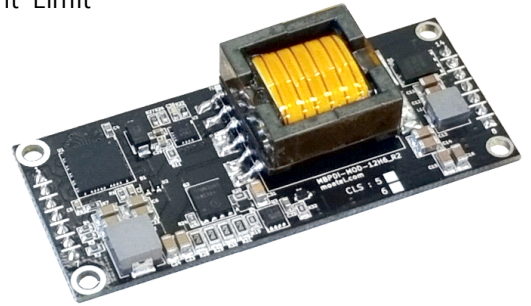

APPLICATION DIAGRAM

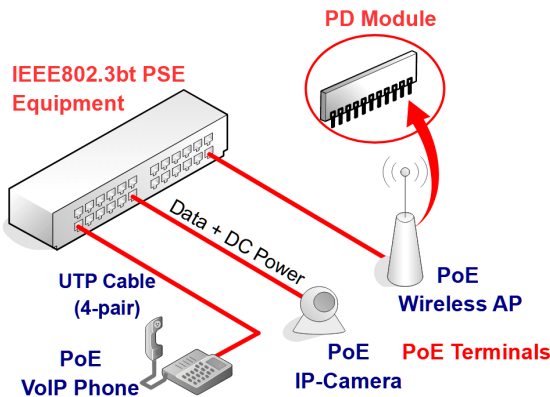

TYPICAL CONNECTION

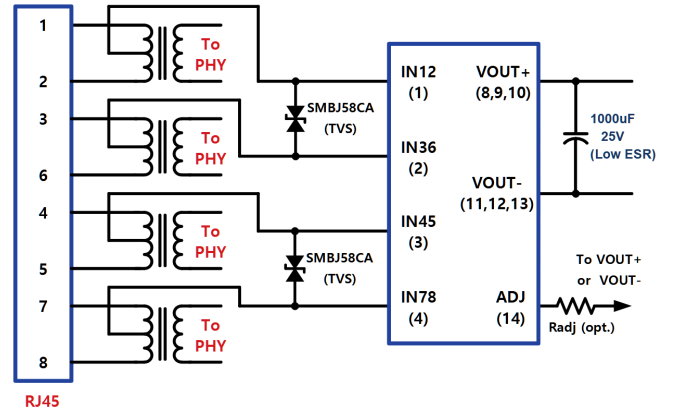

OUTLINE DRAWING

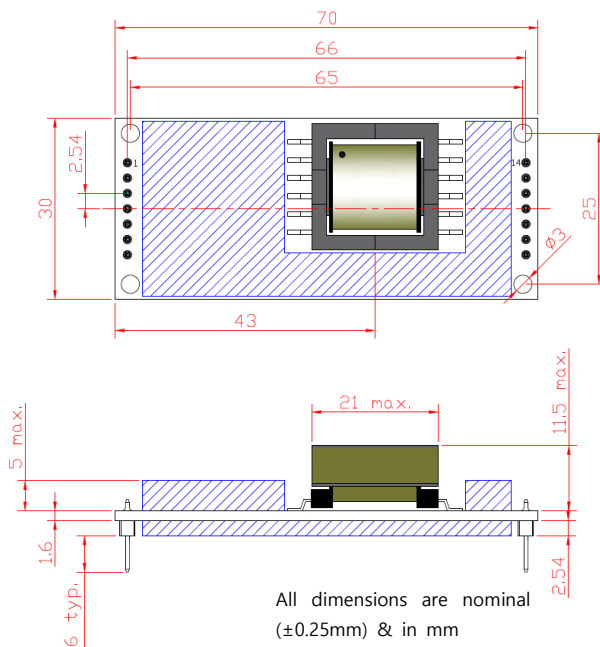

LAYOUT RECOMMENDATION

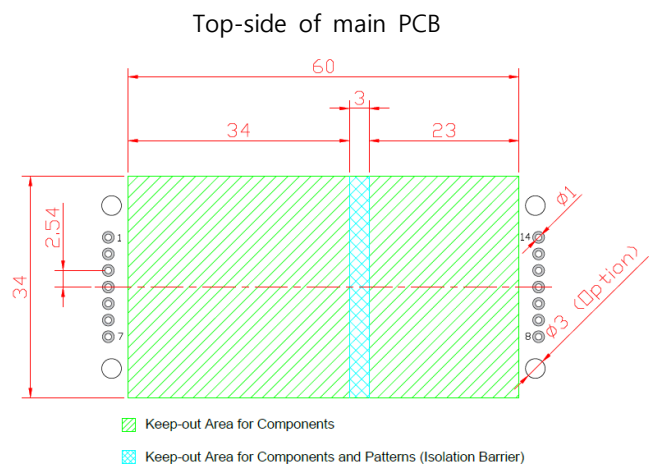

Fix-Hole (3-pi) Notice :

- No Electrical Connections are allowed to 2 fix-holes on the left.
- DGND Connections are allowed to 2 fix-holes on the right.
- All fix-holes are deletable when there is no stand-off(or spacer).
- In case of using stand-off(or spacer), be careful of interference.

PIN ASSIGNMENT

Pin #	Name	Description
1	IN12	Input 12 : This input pin connects to the Center-Tab (1-2) of PoE Interface Transformer for PSE Equipment.
2	IN36	Input 36 : This input pin connects to the Center-Tab (3-6) of PoE Interface Transformer for PSE Equipment.
3	IN45	Input 45 : This input pin connects to the Center-Tab (4-5) of PoE Interface Transformer for PSE Equipment.
4	IN78	Input 78 : This input pin connects to the Center-Tab (7-8) of PoE Interface Transformer for PSE Equipment.
5	T0	ID0 : This output pin is indicated PSE type identification signal #0. (Normally NC)
6	T1	ID1 : This output pin is indicated PSE type identification signal #1. (Normally NC)
7	Pri-GND	Primary GND : This output pin is Reference GND for T0 and T1. (Normally NC)
8,9,10	VOUT+	PD Output : This pin provides the +12VDC output of PD.
11,12,13	VOUT-	PD GND : This pin provides the GND output of PD.
14	ADJ	Output Voltage Adjust : The output voltage can be adjusted from nominal value by connecting an external resistor from this pin to VOUT+ or VOUT-.

SPECIFICATIONS

No	Item	Specification
Electrical Specification		
1	Input Voltage	41~57VDC
2	Output Voltage	12V typ.
3	Maximum Output Current	3.4A
4	OCP (Over Current Protection)	110~130%
5	Line Regulation (Vin=41~57V, Full Load)	1%
6	Load Regulation (Vin=54V, 0.1~Full Load)	1%
7	Ripple & Noise (Vin=54V, Full Load)	100mVp-p max.
8	Efficiency (Vin=54V, Full Load)	90% min.
9	Input to Output Isolation	1500 Vrms
10	Type of DC/DC Converter	Active Clamped Fly-back Type
11	Short Circuit Protection Duration	Inf.
12	Protection	OCP, Short Circuit Protection
Environment Specification		
13	Operating Environment	-20 ~ 50 °C / 10 ~ 80 %
14	Storage Environment	-40 ~ 100 °C / 5 ~ 95 %

PSE IDENTIFICATION CODE TABLE (for Data Link Layer supported PSE)

PN	PD Class	Class Events	PD allocated Power	T0	T1	Ref
MBPDI-MOD-12H5	5	4	40W	1	0	Pri-GND

ADJUSTING THE OUTPUT VOLTAGE LEVELS AND REQUIRED EXTERNAL RESISTORS

Vout	Radj	
	To VOUT+	To VOUT-
12.6V	-	0 Ohm
10V	0 Ohm	-

10/100 Base-T APPLICATION

1~10G Base-T APPLICATION

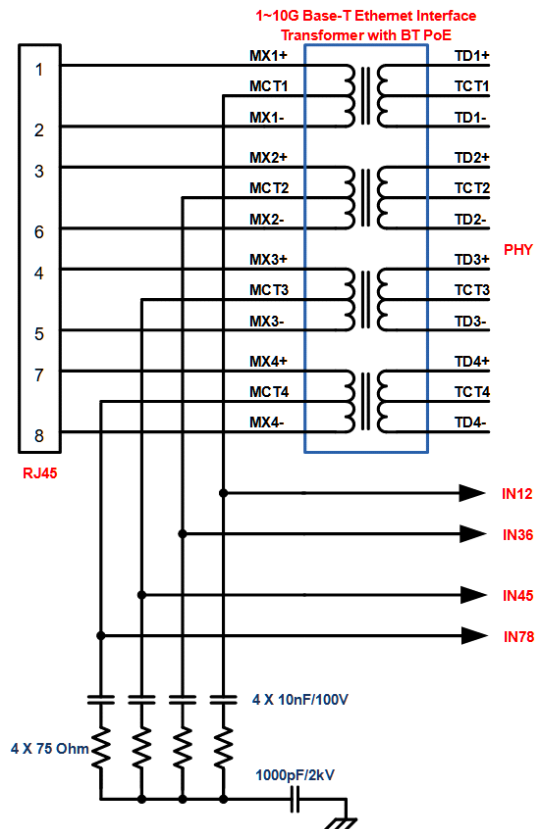
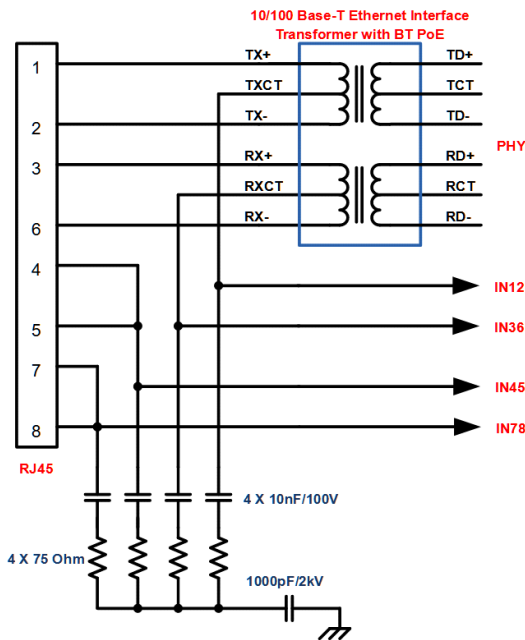

ADVANCED CONNECTION (LOWER NOISE)

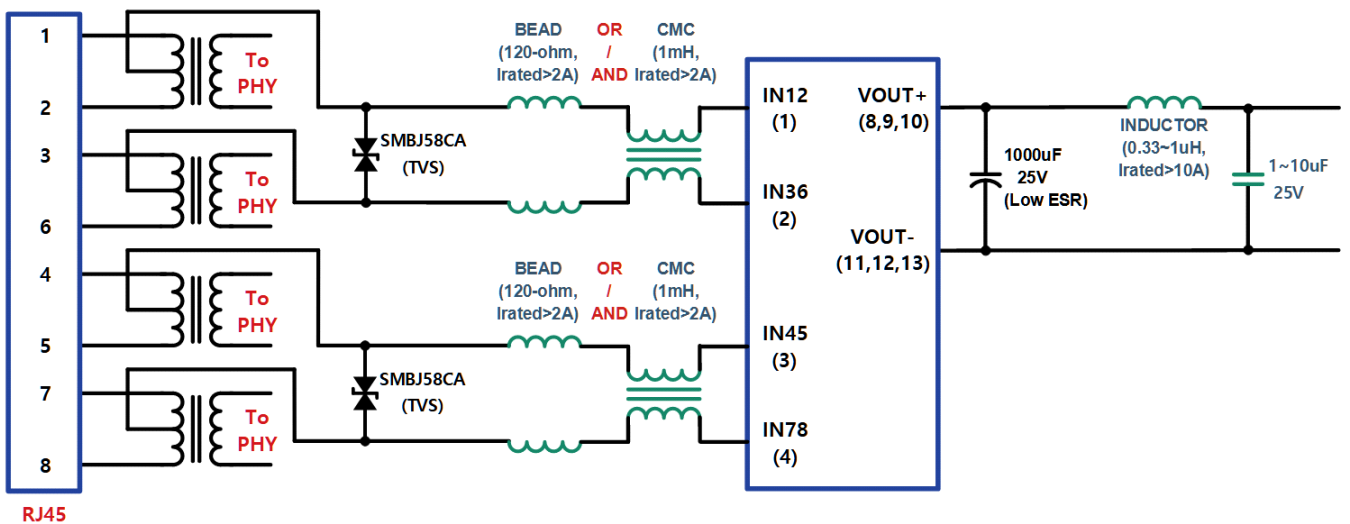

OPTIONAL EXTERNAL SCHEMATIC FOR LOCAL POWER SUPPLY (12VDC Adapter)

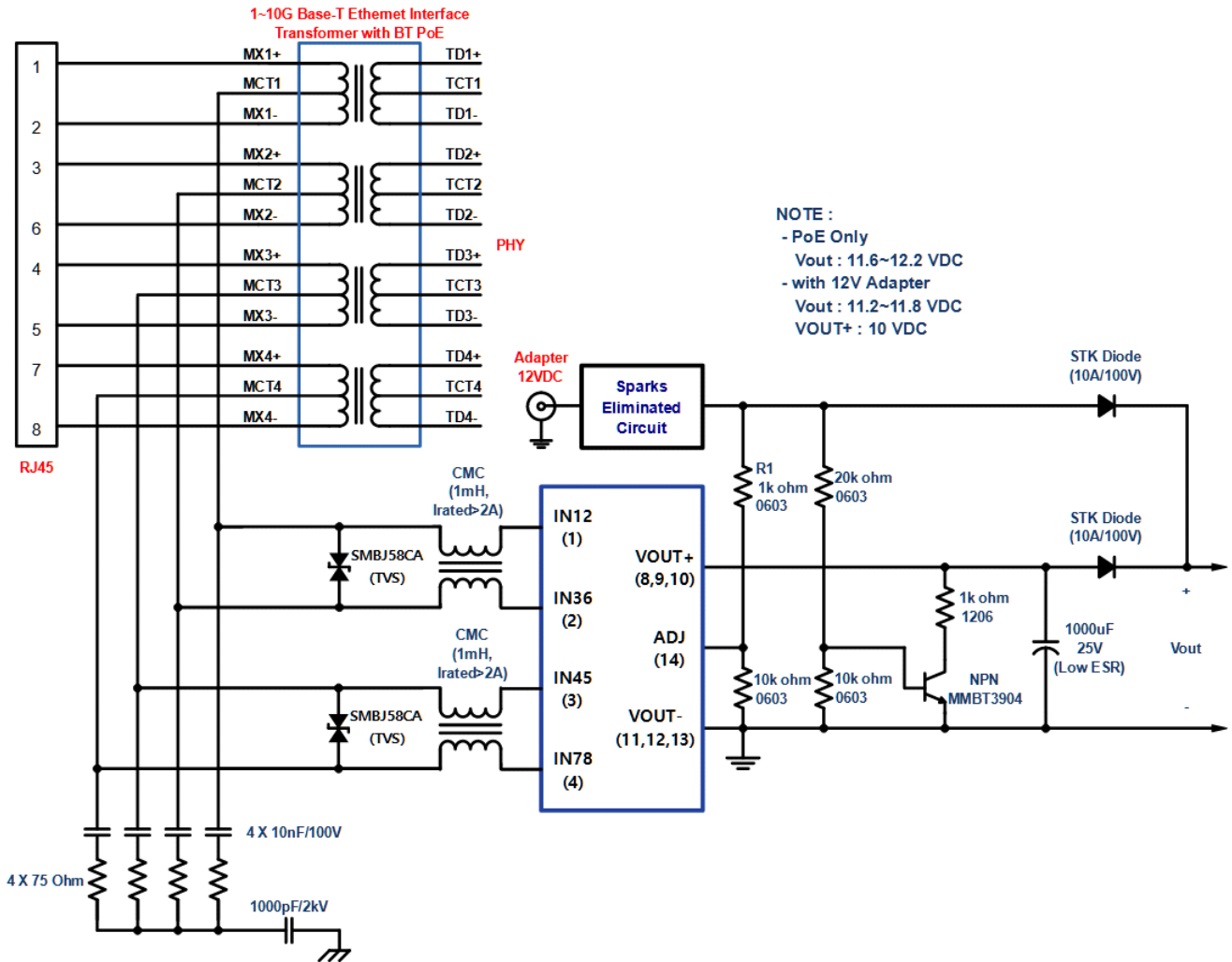

OPTIONAL CONFIGURATION (ONLY for DLL Supported PSE)

